

SAFETY INSTRUCTIONS

⚠ WARNING

1. 120 Volts may cause serious injury from electric shock. Disconnect electrical power before starting installation or servicing. Leave power disconnected until installation/service is completed.
2. Sharp edges may cause serious injury from cuts. Use care when cutting plenum openings and handling duct work.

⚠ CAUTION

1. Read all instructions before beginning installation.
2. Improper installation may cause property damage or injury. Installation, service, and maintenance must be performed by a qualified service technician.

TABLE OF CONTENTS

Introduction and Compliance Statement	2	Set Up	5
Specifications	2	Test	6
Install Electrical Outlet	2	Determine Ventilation Time Setting	6
Ventilator Location and Orientation	3	Start Up and Sequence of Operation	6
Mount the Ventilator	3	Troubleshooting	7
Mount Intake Hood	4	Filter Cleaning	8
Install Ductwork	4	Limited Warranty	8
Wiring	5		

INTRODUCTION AND COMPLIANCE STATEMENT

The Model 8140 & 8141 Fresh Air Ventilators are designed to bring in precisely the right amount of outdoor air into today's efficiently designed homes. Duct the inlet of the ventilator to an outdoor air intake and duct the discharge to the HVAC system, then simply plug the unit in, set the amount of needed ventilation and select the desired temperature limits.

Temperature limits are set on the control to avoid bringing in outdoor air during the hottest or coldest period of the day. The built in control will automatically compensate for the ventilation time that is missed by bringing in additional outdoor air during milder periods of the day. Compliance with the requirements of ASHRAE 62.2-2010 is met as the control adds ventilation time as needed to account for the fractional on-time and effectiveness of the ventilation schedule. The control will also ensure that ventilation occurs no less than one hour of every four. When properly installed and set, the Model 8140 & 8141 Fresh Air Ventilators will meet the mechanical ventilation requirements of:

- Energy Star Certified Homes, Version 3
- EPA Indoor airPLUS, Version 1
- 2012 & 2015 International Residential Code (IRC)
- 2012 & 2015 International Energy Conservation Code (IECC)

SPECIFICATIONS

TABLE 1 – SPECIFICATIONS

External Static Pressure ("w.c.)	Airflow (CFM)	Current (amps)	Power (watts)	Efficacy (CFM/watt)	Voltage
0.0	285	.4	53	5.39	115 VAC 1 phase 60 Hz
0.2	250	.4	53	4.70	
0.4	195	.4	52	3.75	
0.6	130	.4	50	2.62	
0.8	25	.4	44	0.52	

FIGURE 1 – DIMENSIONS (INCHES)

Model 8140 shown.
Model 8141 has identical dimensions.

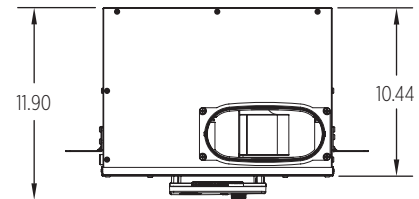
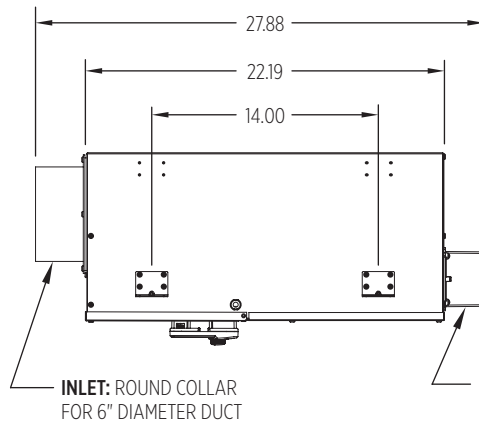
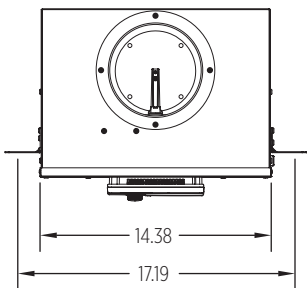

90-2060

INSTALL ELECTRICAL OUTLET

Install a standard NEMA 5-15 receptacle suitable for the location, near where the ventilator will be installed. The ventilator comes equipped with a 6-foot power cord with a standard 3-prong plug.

VENTILATOR LOCATION AND ORIENTATION

⚠ CAUTION

1. Mount the blower with the lowest, exposed moving parts at least 8 feet (2.4 m) above floor or grade level.
2. Mount the blower at least 3.3 feet (1.0 m) from any accessible opening of the duct.

Choose a location for the ventilator that is within 6 feet of the outlet into which the ventilator will be plugged. Allow space for filter removal and service as shown in **FIGURE 2**.

8140 installations: The ventilator can mounted in any orientation.

8141 installations: To ensure proper operation of the backdraft damper on the outlet collar, mount the ventilator with the outlet collar either horizontal as shown below, or angled up. After deciding which orientation the ventilator will be installed, make sure the pivot of the backdraft damper is located above the centerline of the collar (see **FIGURE 3**) to ensure that it closes when the ventilator is off. Remove the outlet collar and rotate it 180° if needed to make sure the backdraft damper functions properly.

FIGURE 2 – CLEARANCES FOR SERVICING

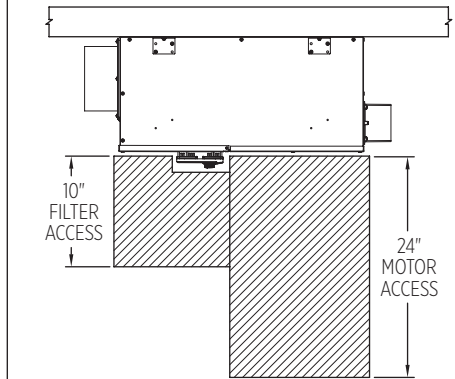

90-2121

FIGURE 3 – OUTLET COLLAR ORIENTATION

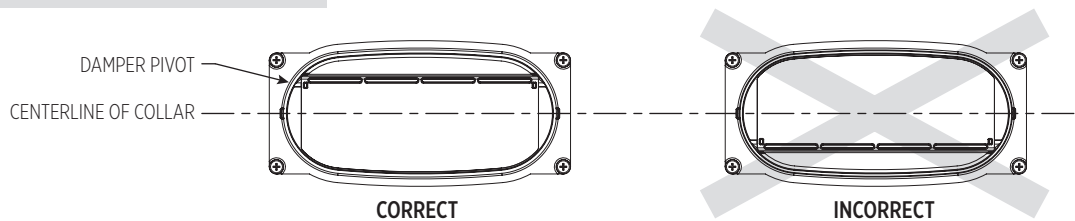

90-2121

MOUNT THE VENTILATOR

1. Install the mounting brackets, using the #8 x 1/2" screws supplied, to the side of the housing as shown in **FIGURE 4**. Use the holes nearest the covers for mounting to floor joists or hanging from rafters. Use the holes near the bottom of the unit for mounting to a flat wall or ceiling surface.
2. Secure the ventilator into joists or a strong platform and screw into place using the #10 x 3/4" screws provided. The ventilator weighs approximately 25 pounds, so do not secure it into drywall alone.
3. Make sure the backdraft damper in the oval outlet collar is positioned so that it will open when the ventilator is on and will close on its own when the ventilator is off. If necessary, remove the collar, rotate it 180° and reinstall.

FIGURE 4 – MOUNTING BRACKET POSITIONING

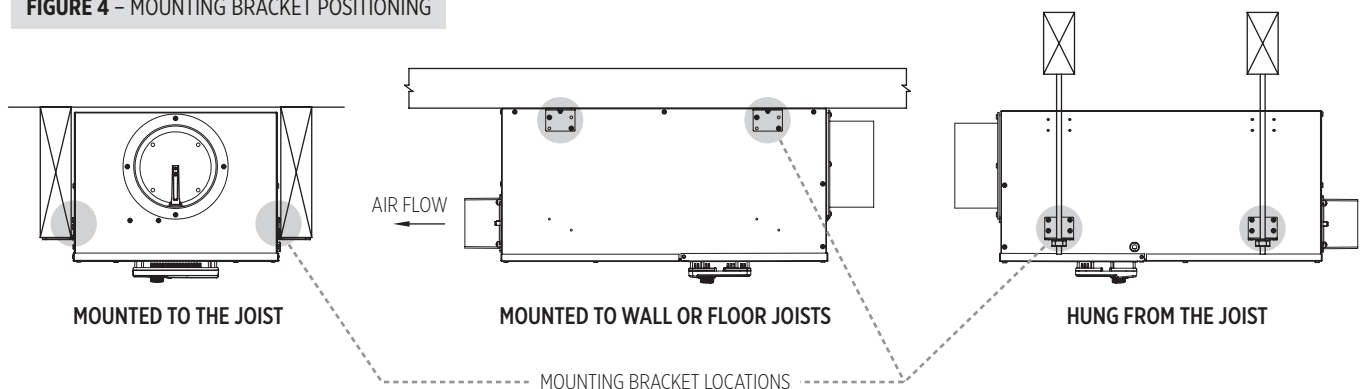

90-2060

MOUNT INTAKE HOOD

Install a weather tight hood with a bird screen.

Cut a hole in the exterior wall that is large enough to fit 6" insulated flexible duct through with minimal compression of the insulation. Pull the duct through the hole and attach the flex duct to the collar of the hood. Use metal foil tape or a plastic zip-tie to secure the duct to the collar. Pull the insulation and vapor barrier over the duct and tape it to the collar.

IMPORTANT: The end of the insulation must be sealed to prevent condensation from forming inside the insulation. If a plastic zip-tie is used to secure the insulation to the hood collar, also tape the end to seal it against condensation problems.

Press the hood against the outside wall and secure in place with screws; seal around the perimeter of the hood with caulk.

INSTALL DUCTWORK

Install 6" diameter flexible, insulated duct from the round inlet collar of the unit to the intake hood and from the oval outlet collar of the unit to the HVAC system.

8140 installations: Duct the outlet of the ventilator to the **return side** of the HVAC system (refer to **FIGURE 5**).

8141 installations: Duct the outlet of the ventilator to the **supply side** of the HVAC system. Discharge the ventilation air into a supply plenum to allow for mixing and/or distribution to multiple registers (refer to **FIGURE 6**).

IMPORTANT: The end of the insulation must be sealed to prevent condensation from forming inside the insulation. If a plastic zip-tie is used to secure the insulation to the hood collar, also tape the end to seal it against condensation problems.

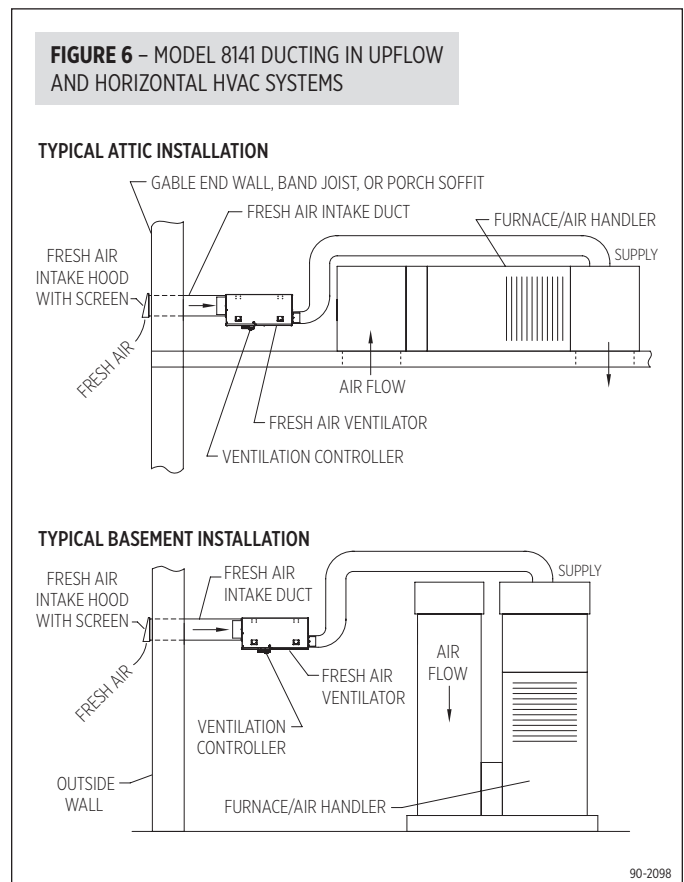
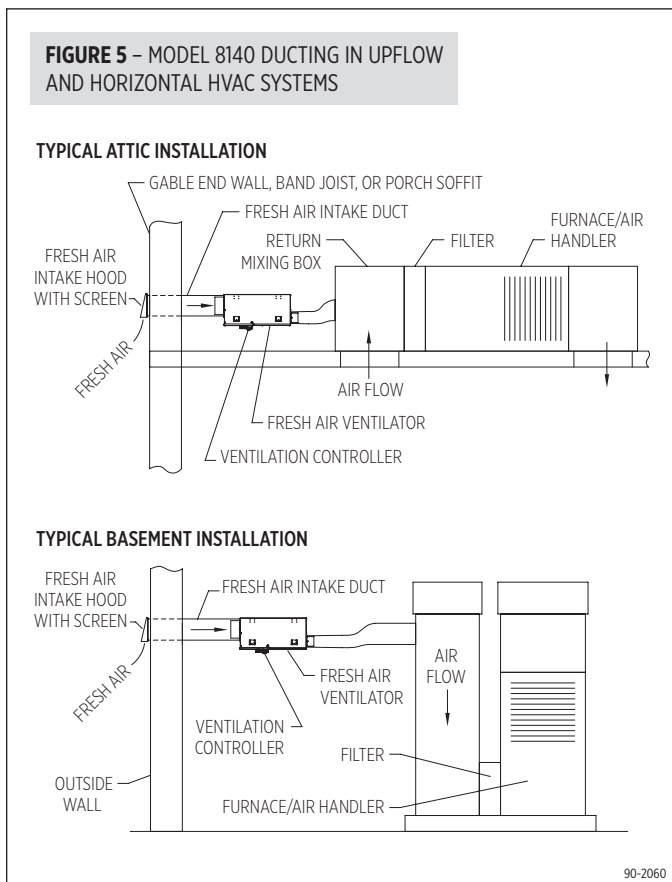

WIRING

The ventilator control is wired to the HVAC equipment as shown in **FIGURE 7** to provide the control with power and to signal the control that the HVAC system is operating. When ventilation is needed but the HVAC system is not running, the ventilator will turn on the HVAC system blower to temper the outdoor air by mixing it with indoor air.

1. Disconnect power to the HVAC system prior to wiring to the HVAC system controls.
2. Run standard thermostat wire (18-22 AWG) as needed between the ventilator, HVAC system and the disconnect switch.
3. Wire as shown in **FIGURE 7** or **FIGURE 8**. Use **FIGURE 7** to ensure the controller turns on the HVAC fan when ventilating. Use **FIGURE 8** to prevent the controller from turning on the HVAC fan.

Optional Disconnect: If the “Minutes per Hour” dial on the ventilator control is not readily accessible, install an optional switch to break the ventilator control “R” wire as shown in **FIGURE 7** or **FIGURE 8**. Label the switch so as to differentiate it from other switches (“Mechanical Ventilation” label is provided in the carton with the ventilator).

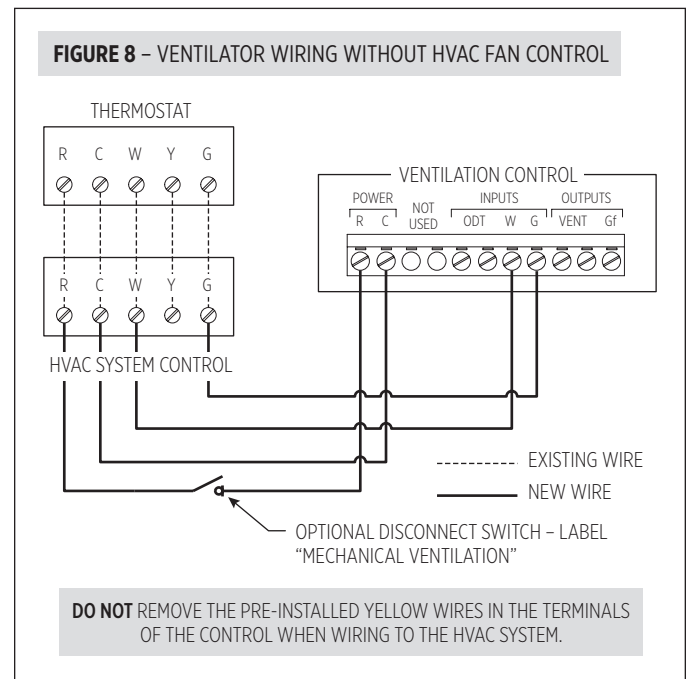
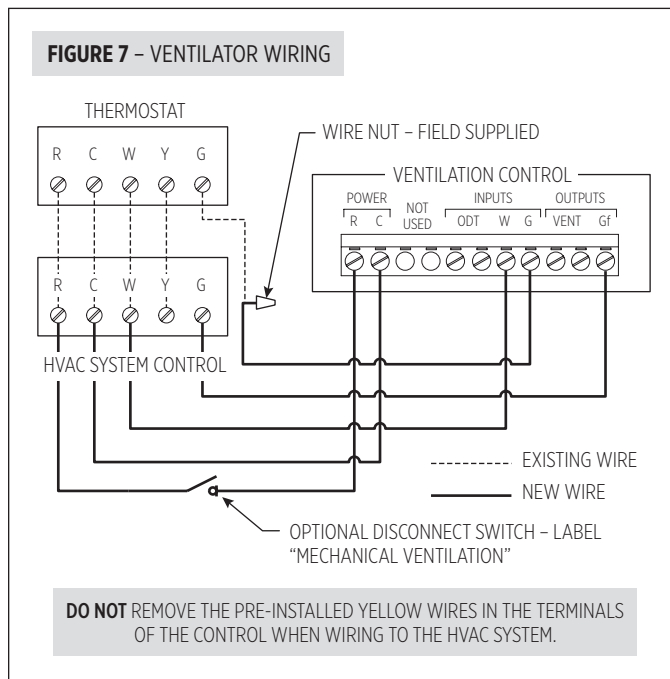

SET UP

The control can be set up to prevent ventilation during the hottest or coldest periods of the day. When the outdoor temperature exceeds the high value or falls below the low value, ventilation will stop and additional ventilation will be brought in at a later time. See **Start Up and Sequence of Operation** section for details.

1. Remove the knob then remove the cover to adjust the high/low temperature limit (see **FIGURE 9**).
2. Use a small flat head screwdriver to turn the potentiometer to select:
 - A – No limit, time only
 - B – 105°F high limit, 20°F low limit
 - C – 100°F high limit, 30°F low limit
 - D – 95°F high limit, 40°F low limit

Select lockouts to prevent ventilation during only the coldest or warmest temperatures for your location.

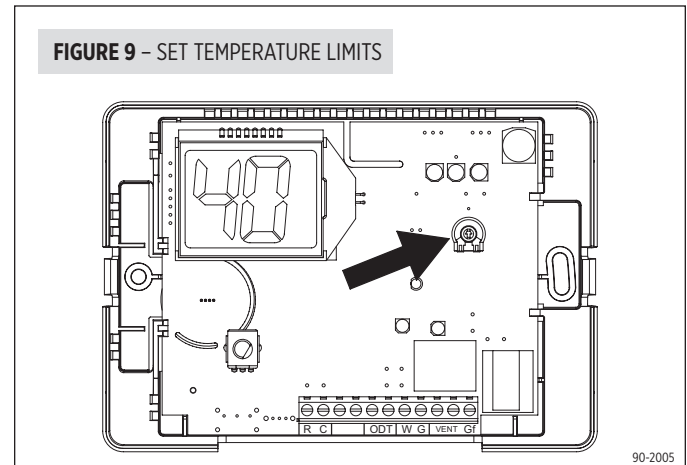

TEST

After all ducting and wiring is complete, plug in the ventilator, restore power to the HVAC system and make sure the disconnect switch, if installed, is turned on. Turn the thermostat to the OFF mode to ensure that wiring the HVAC system has been done correctly and then return it to the desired mode after testing. Rotate the Vent Time setting knob to Test/Reset:

1. The display will show “- -”, the green “Active Ventilation” LED will blink.
2. The ventilator blower will start. For 8140 installations, the integral damper will also open.
3. If the ventilator was properly wired to turn on the HVAC unit blower with ventilation, the HVAC blower will turn on.
4. After one minute the test will end and the display will blink and show the firmware revision level. Return the knob to the OFF position until the desired Time Setting is determined.

DETERMINE VENTILATION TIME SETTING

CALCULATING AIRFLOW REQUIREMENT

1. The MINIMUM ventilation requirement is calculated using ASHRAE 62.2-2010.

ASHRAE Airflow in CFM = [House Area in Sq. Ft. x 0.01] + [(Number of Bedrooms + 1) x 7.5]

Note: Use ‘Number of Bedrooms + 1’ or ‘Number of Occupants’, whichever is larger.

2. **TABLE 2** shows the calculated airflow values to the nearest 5 CFM.
3. Record the required CFM. _____

TABLE 2 – CFM REQUIRED

House Sq. Ft.	Number of Bedrooms					
	2	3	4	5	6	7
1000	35	40	50	55	65	70
1500	40	45	55	60	70	75
2000	45	50	60	65	75	80
2500	50	55	65	70	80	85
3000	55	60	70	75	85	90
3500	60	65	75	80	90	95
4000	65	70	80	85	95	100
4500	70	75	85	90	100	105
5000	75	80	90	95	105	110

MEASURE VENTILATION AIR (CFM) DELIVERY RATE AND SELECT VENT TIME

1. Set the Minutes per Hour knob to 60 minutes to run the blower continuously during measurement. Measure the outdoor air flow (CFM) through the duct that is bringing in outdoor air. Allow 45 seconds after the ventilator starts before taking the measurement so that the powered damper (Model 8140 only) has opened completely.
2. Use the CFM Delivered along with the CFM required to find the Cycle Time per hour setting from **TABLE 3**. For example if the ventilator is providing 120 CFM, and the requirement is 70 CFM, set the time to 35 minutes.

TABLE 3 – CYCLE TIME SETTING (MINUTES) FOR AIRFLOW DELIVERED VS. AIRFLOW REQUIRED FOR 1 HOUR CYCLE

CFM Delivered	CFM Required								
	40	50	60	70	80	90	100	110	120
60	40	50	60						
80	30	40	45	55	60				
100	25	30	40	45	50	55	60		
120	20	25	30	35	40	45	50	55	60
140	20	25	30	30	35	40	45	50	55
160	15	20	25	30	30	35	40	45	45
180	15	20	20	25	30	30	35	40	40
200	15	15	20	25	25	30	30	35	40
220	15	15	20	20	25	25	30	30	35
240	15	15	15	20	20	25	25	30	30
260	15	15	15	20	20	25	25	30	30

START UP AND SEQUENCE OF OPERATION

Set the Ventilation Time knob to the setting that was determined in the previous section. The ventilator will turn on with the HVAC equipment for the set number of minutes during the one-hour cycle period. If the HVAC equipment does not turn on enough the ventilator will turn on and will turn on the HVAC system blower, if wired to do so, at the end of the one-hour cycle period to ensure the desired ventilation time is met. The first time it turns on, it will stay on for five minutes to get an accurate air temperature measurement. If the air temperature is within the range that is set (see Set Up), the ventilator will turn on for the amount of time selected within the one-hour cycle period.

If the air temperature is outside of the set range, then no additional ventilation will occur for another hour, and the cycle period will automatically adjust to four hours. When the ventilator starts again, it will sample the air temperature and if in range, will meet the set amount of ventilation during the four-hour cycle period. For example, if the Vent Time was set to 25 minutes per hour and the first time the ventilator came on it measured an air temperature above the high limit setting, it would turn off after five minutes. The control will automatically change the cycle period to four hours and work to provide the additional 95 total minutes of ventilation (25 min/hr x 4 hours = 100 minutes, minus the five minutes of the first air sampling) during the four-hour cycle period.

If the air temperature is still out of range, the control will automatically switch to an 8-hour cycle period, then a 12-hour cycle period and finally a 24-hour cycle period. During 8, 12 and 24 hour cycle periods, the total ventilation time increases to compensate for ventilation effectiveness as defined in ASHRAE Standard 62.2-2010. When the cycle period automatically adjusts to 24-hours, the control will turn on ventilation to meet the requirements even if the temperature is outside of the set limits.

TROUBLESHOOTING

FIGURE 10 – MODEL 8140 INTERNAL SCHEMATIC

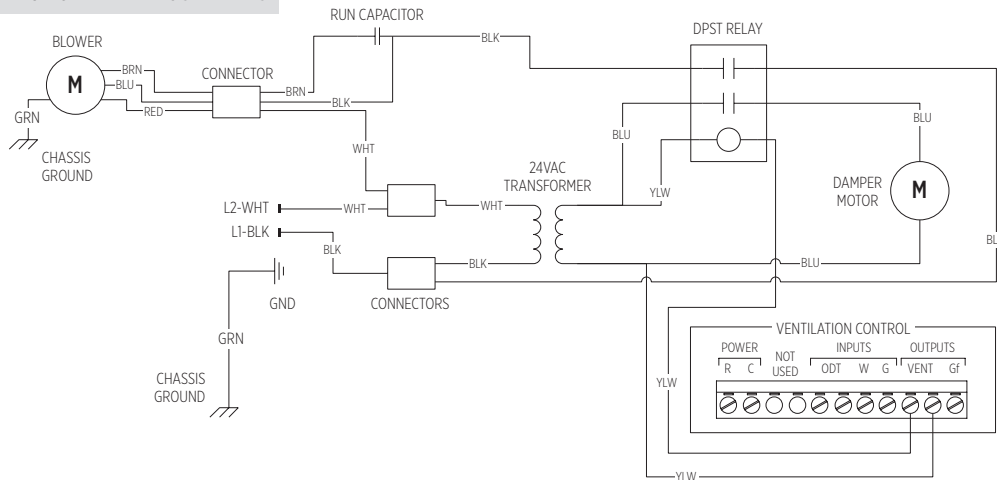

FIGURE 11 – MODEL 8141 INTERNAL SCHEMATIC

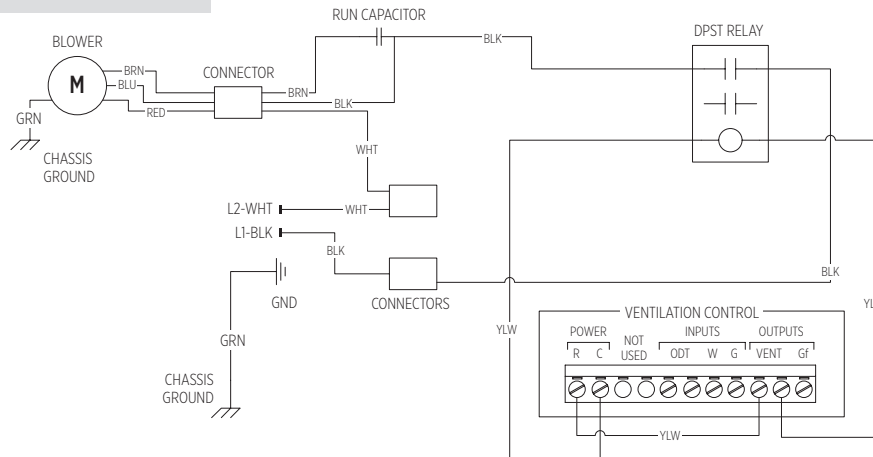

TABLE 4 – TROUBLESHOOTING GUIDE

Symptom	Possible Reason	Correction
Ventilator and display on control do not turn on.	No power to the control.	<ul style="list-style-type: none"> • Wire the control to the HVAC system as shown in FIGURE 7 or FIGURE 8. • Turn on power to the HVAC system. • Turn on the “Mechanical Ventilation” switch.
E3 shows on display.	Sensor inside the control is damaged.	<ul style="list-style-type: none"> • Replace control.
Air is blowing out of the intake hood when ventilator is off.	<p>8141: Backdraft damper is open.</p> <p>8140: Power damper is stuck open.</p>	<ul style="list-style-type: none"> • Make sure the unit is mounted in the proper orientation – outlet cannot point down. • Remove the oval outlet collar and rotate it 180° so that it closes when the ventilator turns off. • Unplug the ventilator (8140 only) and verify that the damper fully closes.

FILTER CLEANING

Normally, the fresh air filter will need to be removed and cleaned every six months, but check it after the first three months following installation to determine if more or less frequent cleaning will be necessary. After cleaning the filter inside the ventilator, clean off the screen at the fresh air intake hood on the outside of the house. The most common cause of reduced ventilation is a clogged air intake hood.

To clean the ventilator filter:

1. Remove the two screws securing the filter door to the housing and swing open the door (**FIGURE 12**).
2. Rotate the plastic filter retainer to release the filter and remove it from the ventilator (**FIGURE 13**).
3. Use water to rinse the filter and shake the excess moisture off the filter.
4. Replace the filter in the ventilator, turn the filter retainer to secure it in the housing, and close and secure the filter door.

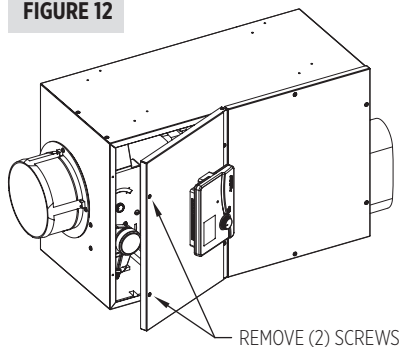
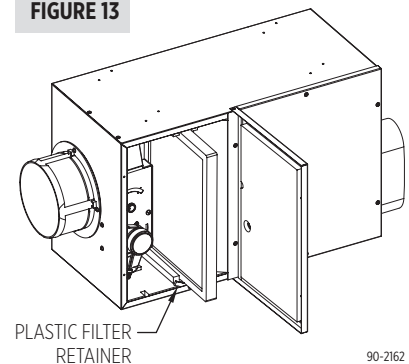
FIGURE 12**FIGURE 13**

LIMITED WARRANTY

Your Research Products Corporation Aprilaire® Fresh Air Ventilator is expressly warranted for five (5) years from date of installation to be free from defects in materials or workmanship.

Research Products Corporation's exclusive obligation under this warranty shall be to supply, without charge, a replacement for any component which is found to be defective within such five (5) year period and which is returned not later than thirty (30) days after said five (5) year period by you to either your original supplier or to Research Products Corporation, Madison, Wisconsin 53701, together with the model number and installation date of the dehumidifier.

THIS WARRANTY SHALL NOT OBLIGATE RESEARCH PRODUCTS CORPORATION FOR ANY LABOR COSTS AND SHALL NOT APPLY TO DEFECTS IN WORKMANSHIP OR MATERIALS FURNISHED BY YOU INSTALLER AS CONTRASTED TO DEFECTS IN THE VENTILATOR ITSELF.

IMPLIED WARRANTIES OF MERCHANTABILITY OR FITNESS FOR A PARTICULAR PURPOSE SHALL BE LIMITED IN DURATION TO THE AFORESAID FIVE YEAR PERIOD. RESEARCH PRODUCTS CORPORATION'S LIABILITY FOR INCIDENTAL OR CONSEQUENTIAL DAMAGES, OTHER THAN DAMAGES FOR PERSONAL INJURIES, RESULTING FROM ANY BREACH OF THE AFORESAID IMPLIED WARRANTIES OR THE ABOVE LIMITED WARRANTY IS EXPRESSLY EXCLUDED. THIS LIMITED WARRANTY IS VOID IF DEFECTS(S) RESULT FROM FAILURE TO HAVE THIS UNIT INSTALLED BY A QUALIFIED HEATING AND AIR CONDITIONING CONTRACTOR. IF THE LIMITED WARRANTY IS VOID DUE TO FAILURE TO USE A QUALIFIED CONTRACTOR, ALL DISCLAIMERS OF IMPLIED WARRANTIES SHALL BE EFFECTIVE UPON INSTALLATION.

Some states do not allow limitations on how long an implied warranty lasts or the exclusion or limitation of incidental or consequential damages so the above exclusion or limitations may not apply to you.

This warranty gives you specific legal rights and you may also have other rights which vary from state to state.

WARRANTY REGISTRATION

Visit us on-line at www.aprilaire.com to register your Aprilaire product. If you do not have on-line access, please mail a postcard with your name, address, phone number, email address, product purchased, model number, date of purchase and dealer name and address to: Research Products Corporation, P.O. Box 1467, Madison, WI 53701

Your warranty registration information will not be sold or shared outside of this company.



AprilairePartners.com
P.O. Box 1467 Madison, WI 53701-1467
800-334-6011 F: 608-257-4357

Printed in USA
©2017 Aprilaire – A division of Research Products Corporation
10011292 B2206783C 4.17